

MB03XL.01

Piccola Tall Basin Mixer tap

meir®



FEATURES

- Refer to the Meir website for warranty terms & conditions, and available finishes.
- Flow rate 6L p/m at 3 bar pressure.
- European components and cartridge
- Solid brass construction
- Box Weight 1.6 Kg

CARE

- Do not install tapware using any form of acetone silicones.
- Do not apply physical items (such as tools) directly to product.
- Never use house-hold or commercial detergents, citrus based cleaners, or abrasive cleaners.
- Clean using a mild washing soap solution rinsed, and dry with a soft cloth.
- Check for any product defects before installation.
- Refer to the installation manual for correct installation.

SPECIFICATIONS

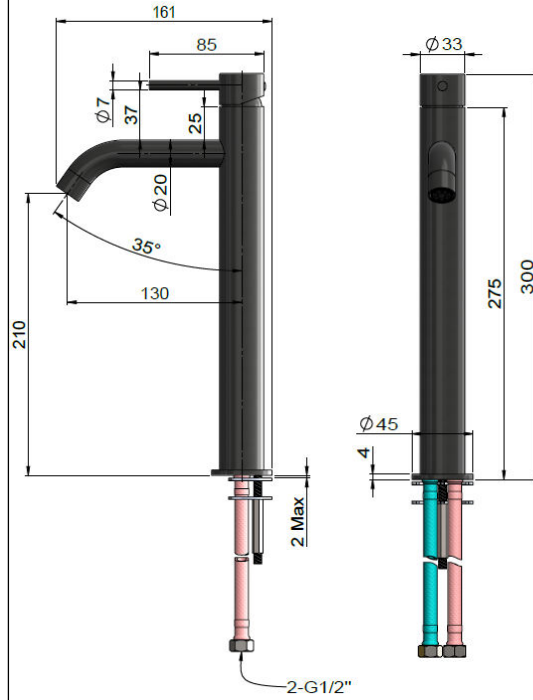

TOLERANCES

Mounting Surface Tolerance

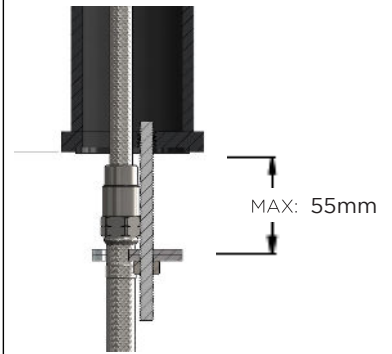

Hole Diameter
MIN: 30mm MAX: 35mm

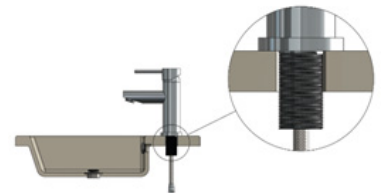

FLOW RATE GRAPH

Test pressure	0.15MPa	0.25MPa	0.3MPa	0.35MPa	0.5MPa
Mixed water - basin mixer	5.5	6.16	6.23	6.25	6.38

Flowchart

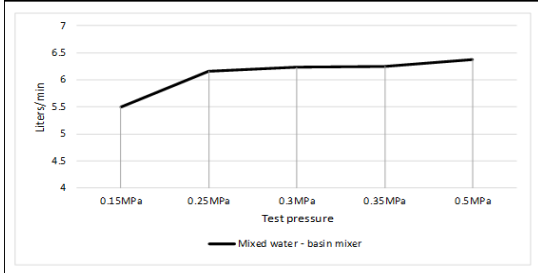

CREDENTIALS

- Watermark AS/NZS3718WMKA25013
- 5-star WELS rated
- 5 litres p/ minute
- WELS registration No: T39426

EXPLODED VIEW

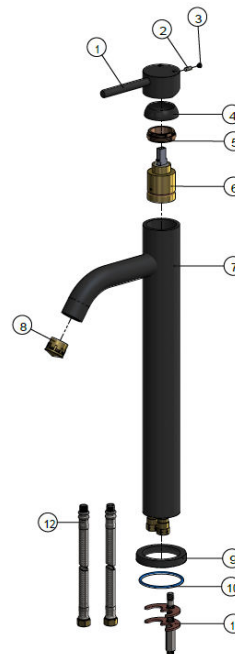

No.	Part Number	QTY
1	Handle	1
2	Screw	1
3	Decor Knob	1
4	Decor Cover	1
5	Nut	1
6	D25 Cartridge	1
7	Body	1
8	Aerator	1
9	Base	1
10	O-ring	1
11	Mounting Fittings	1
12	Inlet Hose	2